

0.5P SERİSİ HİDROLİK DİŞLİ POMPA  
SERIES HYDRAULIC GEAR PUMP

**HATTAT**  
OTOMOTİV PAZARLAMA A.Ş.



TEKNİK BİLGİLER / TECHNICAL DETAILS

**HEMA**  
ENDÜSTRİ A.Ş.

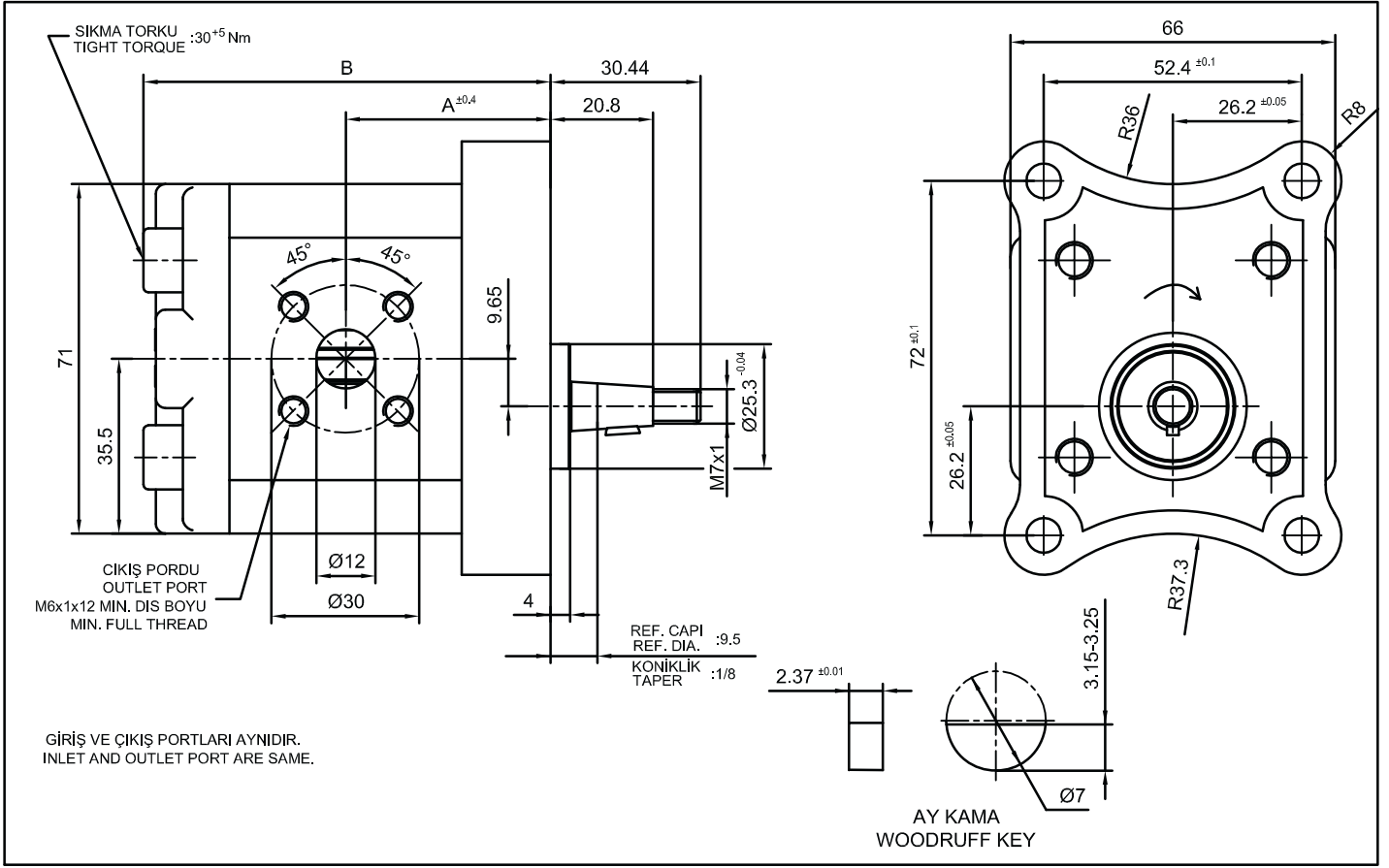

## TEKNİK BİLGİLER-TECHNICAL DATAS

POMPA TİPİ Pump type	İLETİM HACMI Displacement cm <sup>3</sup> /dev (cm <sup>3</sup> /rev)	MAKS.BASINÇ Max. pressure (bar)	MAKS. HIZ Max. speed (d/dak-rpm)	MİN. HIZ Min. speed (d/dak-rpm)	DÖNÜŞ YÖNÜ ROTATION	ÖLÇÜLER-DIMENSIONS	
						A	B
0.5P.011.CB1	1.1	210	3500	1000	SAĞ RIGHT	37.50	74.41
0.5P.016.CB1	1.6	210	3500	1000		38.45	76.43
0.5P.021.CB1	2.1	210	3500	850		39.46	78.44
0.5P.026.CB1	2.6	210	3500	850		40.46	80.45
0.5P.030.CB1	3.0	210	3500	850		41.57	82.66
0.5P.037.CB1	3.7	190	3500	750		42.68	84.88
0.5P.042.CB1	4.2	180	3000	750		43.69	86.90
0.5P.048.CB1	4.8	180	3000	750		44.9	89.32
0.5P.058.CB1	5.8	170	3000	650		46.91	93.34
0.5P.075.CB1	7.5	150	2500	650		50.33	100.19

### ÇALIŞMA ŞARTLARI - WORKING CONDITIONS

Sıcaklık / Temperature : -15°C to 80°C

Kullanılacak yağ - Use oil : Mineral esaslı hidrolik yağlar- Mineral oil based hydraulic fluids.

Tavsiye edilen yağ viskozitesi - Recommended oil viscosity: 15-92 mm<sup>2</sup>s

Filter : Kirlilik sınıfı- Contamination class 10 to NAS1638

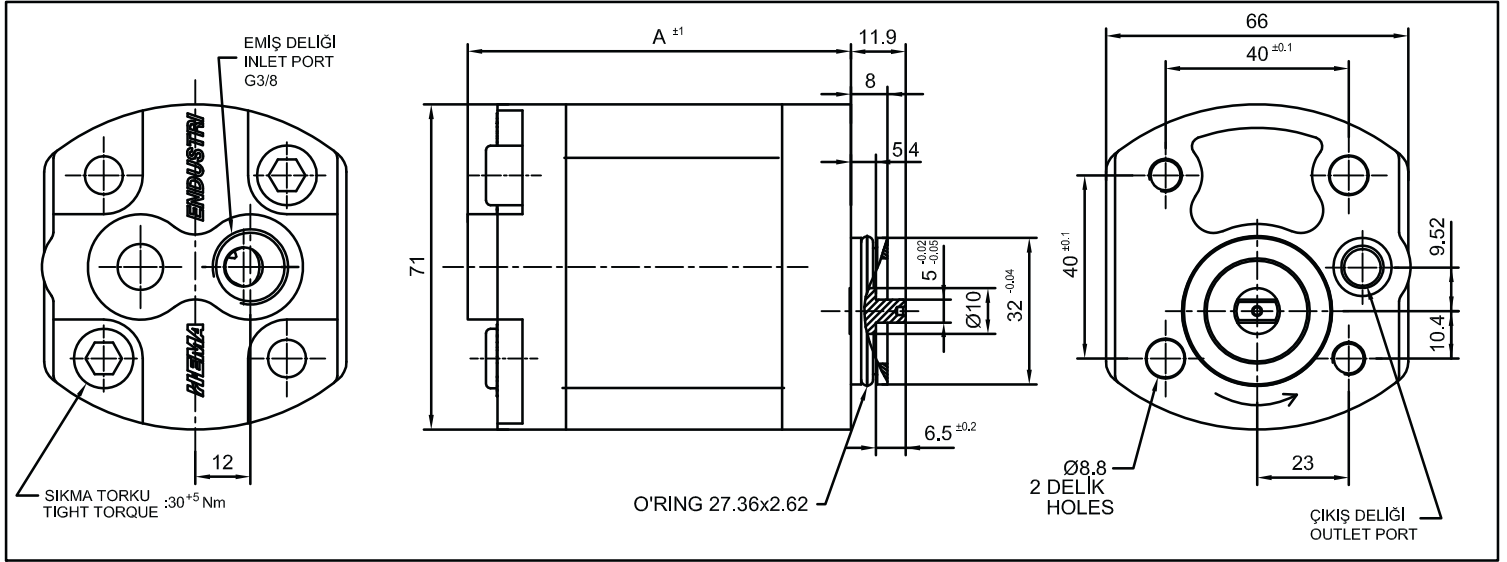

TEKNİK BİLGİLER-TECHNICAL DATAS

POMPA TİPİ Pump type	İLETİM HACMI Displacement cm <sup>3</sup> /dev (cm <sup>3</sup> /rev)	MAKS.BAŞIŒ Max. pressure (bar)	MAKS. HIZ Max. speed (d/dak-rpm)	MİN. HIZ Min. speed (d/dak-rpm)	DÖNÜŞ YÖNÜ ROTATION	ÖLÇÜLER-DIMENSIONS A
0.5P.011.ADR	1.1	210	3500	1000	SAĐ VE SOL RIGHT OR LEFT	75.42
0.5P.016.ADR	1.6	210	3500	1000		77.44
0.5P.021.ADR	2.1	210	3500	850		79.45
0.5P.026.ADR	2.6	210	3500	850		81.46
0.5P.030.ADR	3.0	210	3500	850		83.70
0.5P.037.ADR	3.7	190	3500	750		85.90
0.5P.042.ADR	4.2	180	3000	750		87.90
0.5P.048.ADR	4.8	180	3000	750		90.32
0.5P.058.ADR	5.8	180	3000	650		94.35
0.5P.075.ADR	7.5	150	2500	650		101.20

ALTERNATİF GİRİŞ VE ÇIKIŞ PORT POZİSYONLARI.  
ALTERNATIVE INLET AND OUTLET PORT POSITIONS.

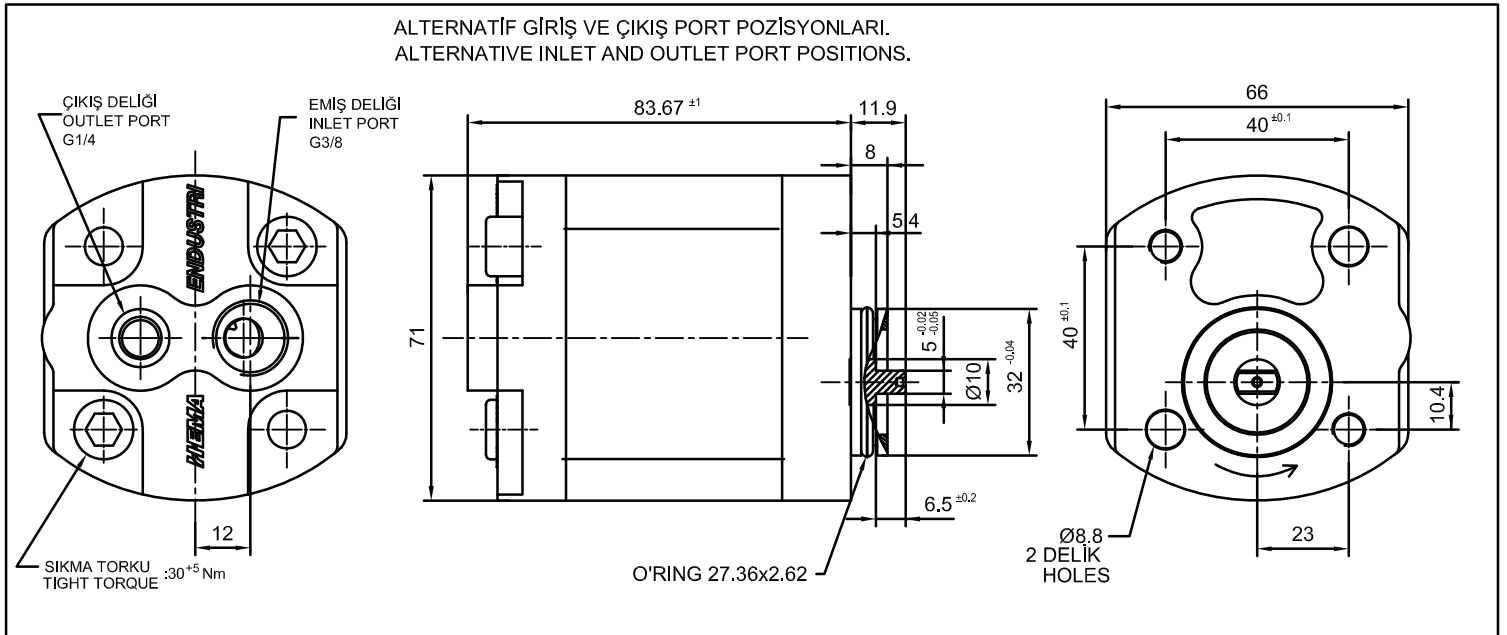

# **HATTAT**

**OTOMOTİV PAZARLAMA A.Ş.**

## **MERKEZ / HEAD OFFICE**

Büyükdere Cad. Üçyol Mevkii No:53  
34398 Maslak / İstanbul / TURKEY  
Phone : +90 (212) 285 22 40  
Fax : +90 (212) 286 44 55

## **FABRİKA / FACTORY**

Organize Sanayi Bölgesi 59501  
Çerkezköy / TEKİRDAĞ / TURKEY  
Phone : +90 (282) 758 10 40  
Fax : +90 (282) 758 10 68

[hattatotomotiv@hattat.com.tr](mailto:hattatotomotiv@hattat.com.tr)  
[www.hattatotomotiv.com.tr](http://www.hattatotomotiv.com.tr)

**444 9 HTT**

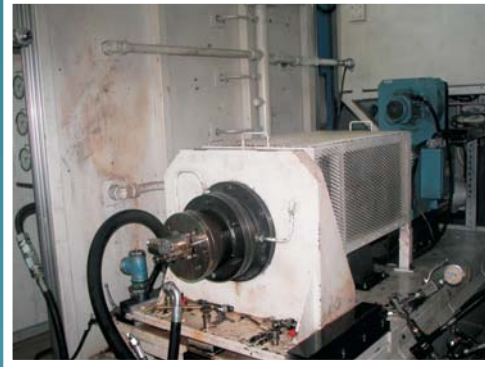

**HEMA**  
**ENDÜSTRİ A.Ş.**